

# Assembly and Installation Instructions for The STRONGBOX II™

Thank you for purchasing the STRONGBOX II™. The STRONGBOX II™ is a larger version of our popular STRONGBOX™ that has been specifically designed to meet the needs of giant scale modelers. The STRONGBOX II™ is a tough molded plastic case that is lined with soft, vibration absorbing foam. The STRONGBOX II™ measures 3.5" deep, 3.3" wide, 6.2" long, and weighs only 3.9 ounces. It is designed to hold both your receiver and a 1200-2000 mA nicad battery pack, protecting them from vibration or crash damage. The STRONGBOX II™ will also hold the new 1200-1300 mA gel-cell battery packs. By following the simple step by step instructions listed below, you can install the STRONGBOX II™ in your airplane, boat or car. The receiver and battery pack are the heart of your R/C system, give them the protection that they deserve.

*Protect your valuables in the STRONGBOX II™.*

**You should have the following parts included in your kit:**

1. Upper case half with foam pad already installed.
2. Receiver foam slice. (3.0" x 5.0" x .875")
3. Separator foam slice. (3.0" x 5.0" x .75")
4. Battery pack foam slice. (3.0" x 5.0" x .875")
5. Lower case half with foam pad already installed.
6. Bag containing the antenna strain relief and 7 screws.  
(3 screws 3/8" long and 4 screws 1/2" long)

**Other items needed for installation:**

1. Two wood mounting rails.
2. A drill with a 3/32" drill bit.
3. A #1 phillips screwdriver.
4. A black felt tip pen.
5. A #11 X-acto knife.
6. Epoxy or thick CA glue.

**Assembly instructions for the STRONGBOX II™:**

1. Locate the .875" thick receiver foam slice. Center your receiver on top of the receiver foam slice. Trace the outline of the receiver onto the foam using a black felt tip pen. Using a sharp #11 X-acto blade, cut out the center of the receiver foam slice. When you are finished, the receiver should nest into the center of the receiver foam slice.
2. Locate the .875" thick battery foam slice. Center your battery pack on top of this foam slice. As in step 1, trace the outline of the battery pack onto the foam slice and cut out the center with a sharp #11 X-acto blade. When you are finished the battery pack should nest into the center of the battery foam slice.
3. Cut two mounting rails from 3/8" x 1/2" spruce stock or from a strip of 1/2" wide plywood that is 1/4" thick. These rails should be long enough to reach from side to side in your model's fuselage.
4. Install the mounting rails into your model using the lower case half as a guide. The lower case half must not be allowed to touch the bottom of the fuselage. A small scrap of 1/4" balsa can be used as a spacer under the lower case half to position the mounting rails. Use epoxy or thick CA glue to secure the rails into the model. After the rails are installed, the spacer can be removed to allow clearance between the bottom of the lower case half and the floor of the fuselage.
5. Using the lower case half as a template, mark the position of the 4 mounting screws on the wood rails that were installed in step 4. Drill a 3/32" hole at each of these 4 marks. Fasten the lower case half to the wood rails in the model using the four #4 x 1/2" sheet metal screws making sure that the end of the case that has two raised bosses faces towards the servos.
6. Place the battery pack foam slice in the lower case half. Set the battery pack in the hole in the foam piece with the wire lead pointing out towards the servos between the two raised bosses.
7. Take the antenna strain relief and weave the antenna through it. The antenna should go through one of the end holes first, through the other end hole, and then up through the middle hole. The strain relief should be placed about 2" from the receiver.
8. Plug the switch harness into the receiver and the battery pack. Plug all of the servo leads and servo extensions into the receiver. Place the .75" thick separator foam slice on top of the battery pack.

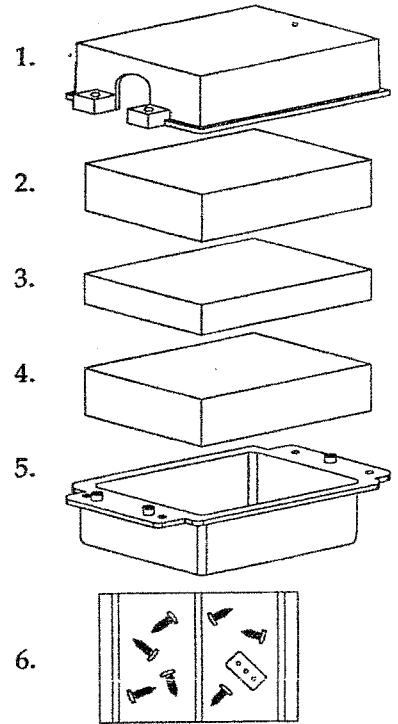

(Instructions continue on opposite side.)

© 1993 LDM Industries, Inc.

9. Set the receiver foam slice on top of the separator foam slice. Set the receiver in the hole in the receiver foam slice with the servo leads pointing towards the servos.
10. Pick up the upper case half. Route the antenna through the small hole in the upper case half. The antenna should go from the inside of the upper case and exit on the outside of the upper case.
11. Align the stack of foam blocks in the lower case half and slide the upper case half in place. Pull lightly on the antenna wire while sliding the upper case half in place to make sure that the strain relief rests against the top of the case.
12. Press the upper case half down, compressing the foam blocks, and secure the upper case half to the lower case half with the three #4 x 3/8" sheet metal screws.
13. This completes the installation of the STRONGBOX II™. All that is left to do is mount the switch harness to the side of the model. **NOTE:** If your fuselage is too wide to allow the switch harness to reach from the STRONGBOX II™ to the fuselage side, you may cut a hole in the top case opposite the end where the antenna comes out, mount your switch inside the STRONGBOX II™ and activate the switch remotely with a piece of music wire. This modification will not void your warranty.

### **LIMITED WARRANTY**

The STRONGBOX II™ is warranted against defects in materials and workmanship for a period of 180 days from the date of purchase. During this period, LDM Industries Inc. will replace any components found to be defective. This warranty does not cover any unit that has been improperly installed, abused or altered. Under no circumstances will the purchaser be entitled to consequential or incidental damages resulting from the use of this product. This Limited Warranty gives you specific legal rights. You may have other rights which vary from state to state. Installation and use of this product shall constitute compliance with this warranty.



**LDM Industries, Inc.**

*Quality R/C Model Products • Since 1984*

*Now owned & manufactured by . . .*

**SONIC-IRONICS** INC.

7865 Mill Road  
Elkins Park, PA 19027 USA  
Tel. 215 635 6520 FAX 215 635 4951